

# Valley<sup>®</sup> Product Catalog



RELIABLE

DURABLE

PRECISE

ADVANCED

RESPONSIVE



# Why should you choose Valley®?

What makes Valley® equipment unique? The Valley brand of center pivots, corners, and linears by Valmont Irrigation lead the industry in combining technology with high functionality. The Valley brand is known for having the most durable structures, advanced technology, and wide spread product distribution making it the first choice among those wishing to increase the value of their land with irrigation equipment. The Valley brand lasts longer, performs better, and depreciates at a slower pace than other brands allowing you to realize the lowest total cost of ownership.

## The Valley brand leads the world in precision irrigation and is the founder of the industry

The Valley brand of center pivots, corners, and linears:

- are chosen 2-1 over competitor brands
- have the lowest total cost of ownership
- have a widespread product distribution network with 7 manufacturing facilities and 5 parts distribution centers worldwide
- are backed by the most knowledgeable dealers in the industry
- are run by the strongest gearbox which is the only irrigation gearbox Made in the USA
- have a higher resale value than competitive machines



## Valley offers not only the best machine but also the best technology

Valley irrigation technology:

- offers the most advanced control and monitoring technology for irrigation equipment
- can be utilized on a variety of mobile devices
- includes the BaseStation product, an industry exclusive, that allows monitoring and control from a few to hundreds of center pivots

### Valley Started an Industry – Mechanized Irrigation

<ul style="list-style-type: none"> <li>• Water Drive</li> </ul>	<ul style="list-style-type: none"> <li>• First galvanized Water Drive</li> </ul>	<ul style="list-style-type: none"> <li>• Model 4000 pivot - with rubber tires, gear drive</li> </ul>	<ul style="list-style-type: none"> <li>• Pivot introduced with Corner</li> <li>• 2-wheel E-Z Towable</li> <li>• Valley® Gearbox</li> </ul>	<ul style="list-style-type: none"> <li>• Linear (Rainger and Universal) System</li> <li>• Ditch or hose feed linear</li> <li>• Low-pressure sprinklers</li> </ul>	<ul style="list-style-type: none"> <li>• Model 6000 pivot</li> <li>• Valmonitor - computer aided scheduling</li> </ul>
1954	1964	1974		1984	

# What's Inside

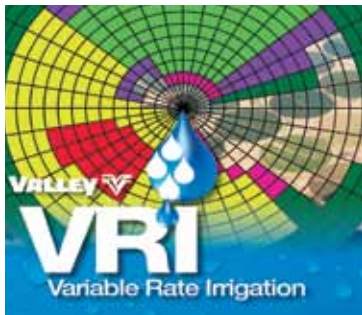

## Variable Rate Irrigation (VRI)

- Exclusive precision ag irrigation management technology with Valley control panels
- VRI Speed Control
- VRI Zone Control



## Valley TouchPro™

- Simplify control panel programming
- Personalize screens
- New touch technology

## Longest Span in the Industry

- 225' span
- Allows you to cover more acres with fewer drive units and spans



## Bender160™

- Pick up additional acres on part-circle pivots
- Bends up to 160 degrees in either or both directions

## GPS Ready Controls

- TouchPro, Pro2, Select2, AutoPilot Linear
- Simplifies the use of GPS technology
- GPS Position calculations performed in the control panel



# Contents

- Center Pivots..... 4
- Corners ..... 6
- Benders and Drop Span..... 7
- Smaller Field Options..... 8
- Linears ..... 9
- Reliable Drive Train ..... 10
- Durable Structure ..... 12
- Control Panel Options..... 14
- Advanced Control Technology ..... 16
- Variable Rate Irrigation ..... 18
- Water Application ..... 19
- Pipeline Solutions ..... 20
- Floatation Solutions ..... 21
- Available Options..... 22
- Conversions / Upgrades..... 23
- Worldwide Leadership ..... 24

Visit  
**CirclesForRice.com**  
 for the latest information  
 on the Valley Irrigation rice  
 under pivots project



<ul style="list-style-type: none"> <li>• cams™ Pro Panel</li> <li>• cams™ BaseStation</li> <li>• Modular Panel Design</li> <li>• Remote Pivot Control</li> </ul>	<ul style="list-style-type: none"> <li>• Model 8000 pivot</li> <li>• PolySpan®</li> <li>• Precision Corner™</li> <li>• Remote Link</li> </ul>	<ul style="list-style-type: none"> <li>• Data Radio &amp; Auxiliary Link packages</li> <li>• Valley Tracker™</li> </ul>	<ul style="list-style-type: none"> <li>• Valley TrackerSP</li> <li>• 7000 series</li> <li>• BaseStation2</li> </ul>	<ul style="list-style-type: none"> <li>• Tracker2</li> <li>• GPS Ready Controls</li> <li>• VS-7000 Gearbox</li> <li>• valleytracker.com</li> </ul>	<ul style="list-style-type: none"> <li>• BaseStation2-SM</li> <li>• Circles for Rice</li> <li>• Variable Rate Irrigation</li> <li>• TouchPro Control Panel</li> </ul>
					
1994			2004		2012

# 8000 series Center Pivot



The top-of-the-line, Valley 8000 series was engineered for long durable life and has been field tested to handle the most demanding terrain and operating stresses any machine could experience. Take advantage of the benefits this machine has to offer such as: the longest span in the industry at 225' and options to ensure maximum field coverage, such as bender and corner products.

## 8000 series Specifications

- 6 5/8", 8", 8 5/8", or 10" pivot point options
- 6", 6 5/8", 8 5/8" and 10" pipe diameter options
- 2, 5 or 7.5 HP booster pump
- Maximum machine length up to 24 spans covering 2800'

## Accelerated Structural Life Cycle Test Comparison

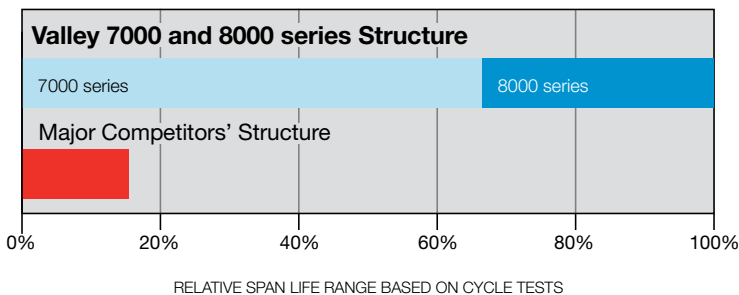

Valley has developed a standard, accelerated life cycle test based on past field performance for both Valley and competitive spans so you can see how they match up. This test subjects the spans to conditions that the span could experience on rough ground with large tires. The span with the longest cycle test life can be expected to last the longest in similar field conditions.

These test results shown to the left were certified by an independent professional engineering consultant and prove Valley spans on average last 5 to 6 times longer than our closest competitors' spans.

## Structure Options for Different Crop Heights

### Standard Profile Drive Units

- Clearance: 9' 4" – 10' 0"

### Low-Profile Drive Units

- When standard clearances are not required
- Low-Profile clearance: 6' 2" – 6' 5"

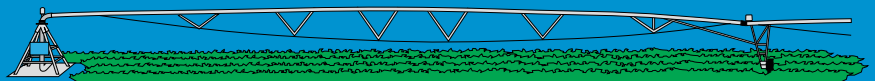

\*Actual clearances in the field will vary based on wheel track depths, span lengths, field terrain and various operating conditions.

**The Most Durable Pivot in the Industry, and now the longest span in the Industry at 225'!**

# 7000 series Center Pivot



Engineered and developed as a cost-effective irrigation solution for growers looking for choices, the Valley 7000 series is second only to the industry leading Valley 8000 series for reliability, durability and overall performance.

### 7000 series Specifications

- 6 5/8" or 8" pivot point options
- 6" and 6 5/8", 8 5/8" pipe diameter options
- 2 or 5 HP booster pump
- Maximum machine length of 1500'

### VS-7000 Gearbox

The VS-7000 gearbox is a high quality, durable gearbox offered at a lower price point. Many of the features that make Valley gearboxes the industry's leader are included, such as ductile worm for longer gear life and extended output shaft for improved seal life. The VS-7000 gearbox has proven to be the second best gearbox in the industry.

VS-7000 Gearbox and Classic Control Panel options are only available on the 7000 series

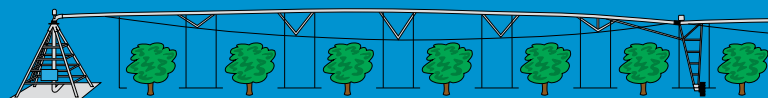

### High-Profile and Ultra-High Profile Drive Units

- Provide increased crop clearance
- High-Profile clearance: 13'0" – 13' 3"
- Ultra-High Profile clearance: 16' 3" – 16'6"

**An Economical Solution for Your Operation!**

# Valley Corner Machines

Valley Corner machines help you earn extra income from the land you already have. No matter what crops you raise, Corners take acres that have previously been without irrigation and put them into production—for far less than the cost of acquiring more land.

For example, on a square quarter-section, a Valley Corner machine enables you to irrigate an extra 23 acres that a center pivot alone can't reach. On odd-shaped and irregular-shaped fields, you can add as many as 49 extra acres. On rectangular fields, the machine can swing out to pick up both ends, adding an extra 37 acres.



Valley Corner with GPS Guidance

## Valley Corner

- Rugged, low profile joint connects corner arm to last regular drive unit
- Extended cradle to handle deep ridges with a long travel interval for smooth movement
- Each sprinkler is controlled hydraulically for long life and accurate water application
- Self-flushing filter ensures clean water for reliable sprinkler control
- Buried wire or GPS Guidance available for precise track-on-track path control
- Operates in a “trailing” mode
- Available on both 7000 series and 8000 series

## Valley Precision Corner



- Comes standard with more sprinkler sequencing options than any other corner arm in the industry to provide uniform water application
- Offers the ability to accurately apply crop protection chemicals and fertilizers
- Operates with the patented Valley Corner control panel which allows you to monitor speed and pressure for efficient use of pump capacity
- Has the ability to operate in a “leading” or “trailing” mode to best fit the field
- Longer span lengths available to provide greater coverage
- Available on 8000 series



Valley Precision Corner

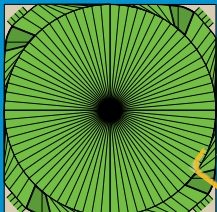

Water Utilization Package

## Water Utilization Package™ (available on Valley Precision Corner only)

When you have a water utilization package, additional solenoids control 22 more sprinklers for maximum water application uniformity in select corner areas as shown by the darkened areas in the photo to the left. This product delivers the required water to maximize crop yields for the entire field.

**Contact your Valley Dealer about water application solutions for your field!**

# Valley Benders

The Bender options were introduced to maximize irrigated area. The Bender30™ and Bender160™ allow the outer portion of a pivot to continue moving while the inner portion is stopped by fences, trees, and other obstacles. With the Valley Benders you receive improved water application while maximizing your irrigated acres because of the exclusive speed-up timer which can be set to increase the speed of the center pivot up to 100% to reduce over watering while bending.

## Bender30™

- Bends up to 30 degrees in either direction
- Utilizes existing structural components – easy to retrofit to an existing center pivot
- Multiple Bender30 units can be installed on one pivot
- Exclusive speed-up timer from Valley helps improve water application performance while bending



## Bender160™



- Bends up to 160 degrees in either direction
- Utilizes custom structural components
- Multiple Bender160 units can be installed on one pivot
- Exclusive speed-up timer from Valley helps improve water application performance while bending

# Valley Drop Span

The Valley Drop Span utilizes custom structural components and allows the outer spans of your center pivot to be “dropped” from the machine which allows you to pick up additional acres that are adjacent to large obstructions at the edge of the field. The spans can be dropped or re-attached by one person without tools in less than 15 minutes!



### Features

- Large platform for easy access
- Optional second end gun
- Large, easy-to-access coupling with tethered plug
- Simple electrical connector manages span cable and control logic. No re-wiring needed
- Simple winch and batten leg system to drop and re-attach outer spans
- Stop switch automatically aligns base machine with dropped spans for easy re-attachment

# Smaller Field Options



## Valley® 5000 series

The Valley 5000 series has been developed to provide a cost effective irrigation solution for smaller fields up to 60 acres. This durable machine was created specifically for production agriculture and comes with the reliability and aftermarket support that only Valley dealers can provide. The Classic control panel is available for the 5000 series basic operations.

### 5000 series specifications:

- 5" diameter pipeline
- 820' maximum machine length
- 108" outlet spacing
- 112.5' – 202.5' span lengths
- 1HP booster pump option
- Single-phase power option
- One towable design option uses a 3-point hitch for easy towing with a category 2 or 3 tractor hitch

## Single Span Spinner Drive

The Valley Single Span Spinner Drive is designed to address the needs of growers with small fields or limited access to electricity. This single span pivot is driven by water pressure and offers all of the structural and mechanical advantages of any Valley center pivot.



## Single Span Engine Drive

The Valley Single Span Engine Drive is the ideal option for irrigating small fields up to 6 acres wherever electric power is not readily available. All sprinkler packages are available to deliver efficient water applications with low water pressure, providing significant energy, labor and water savings.



## Towable Pivots

Valley towable pivots provide another solution for growers who have a need for irrigation on their smaller production ag fields. Because these machines can be moved from one field to another, growers can economically irrigate more acres with one center pivot. Towable options include: Quick Tow, 2-Wheel E-Z Tow, and 4-Wheel E-Z Tow.

**Valley has the right machine for every field!**



# Valley Linears



## Valley Rainger™

Based on a common cart platform, the Valley Rainger cart may be equipped to take water from either a ditch or a hose. The cart can also be customized by adding options, such as chemigation and fertigation tanks.



## Valley Rainger Swing-Around™

The swing-around option of the Valley Rainger Linear can be configured to cover a wide range of field widths. The linear spans rotate around the cart 180 degrees, which provides an economical solution that gives the grower the opportunity to more than double the amount of land irrigated with one machine.



## Valley Universal

The Valley Universal Linear is designed for swing-around applications. Unlike other swing-around linears, the Universal can be programmed to automatically switch between linear mode and pivot mode, allowing the grower more time to attend to other aspects of his operation.



## Valley Two Wheel Hose Feed

The Two Wheel Hose Feed Linear from Valley is an ideal conversion option for fields currently irrigated by flood, drip, or solid set. This versatile machine may operate as a standard linear, towable, or swing-around.



## Valley Two Wheel Ditch Feed

The Valley Two Wheel Ditch Feed Linear can take advantage of either permanent earthen water delivery infrastructures or earthen ditches that are installed annually. This linear is ideal for small fields, as it can either be towed or swung around to cover more area. A flexible suction will keep the investment costs low by fitting nearly any functioning earthen ditch.

# Reliable Drive Train

The patented Valley Gearbox is designed and built in Valley, Nebraska, USA. It is constructed to work under today's most demanding conditions. There's a stronger, heavier bull gear and pre-loaded worm gear that keep oil in and problems out. A heavy-duty bronze bull gear is an available option for severe field conditions.

## Valley Gearbox... American Made. Valley Strong.

**Large capacity rubber diaphragm** — expands with heat and pressure to minimize water condensation.

**Input and output bearings** — American made and case hardened to provide the highest quality and load rating available in the industry.

**Worm gear** — high strength ductile iron provides significantly longer wear life than steel when combined with a cast iron bull gear.

**Tooth design** — industry exclusive 25° tooth angle provides 40% longer life and better reliability in tough conditions compared to normal 14½° tooth designs.

**Largest bull gear neck and keyway** — for strength in critical load-bearing area.

**All these factors add up to one thing** — the best quality gearbox in the industry, giving you long, trouble-free economical equipment life.

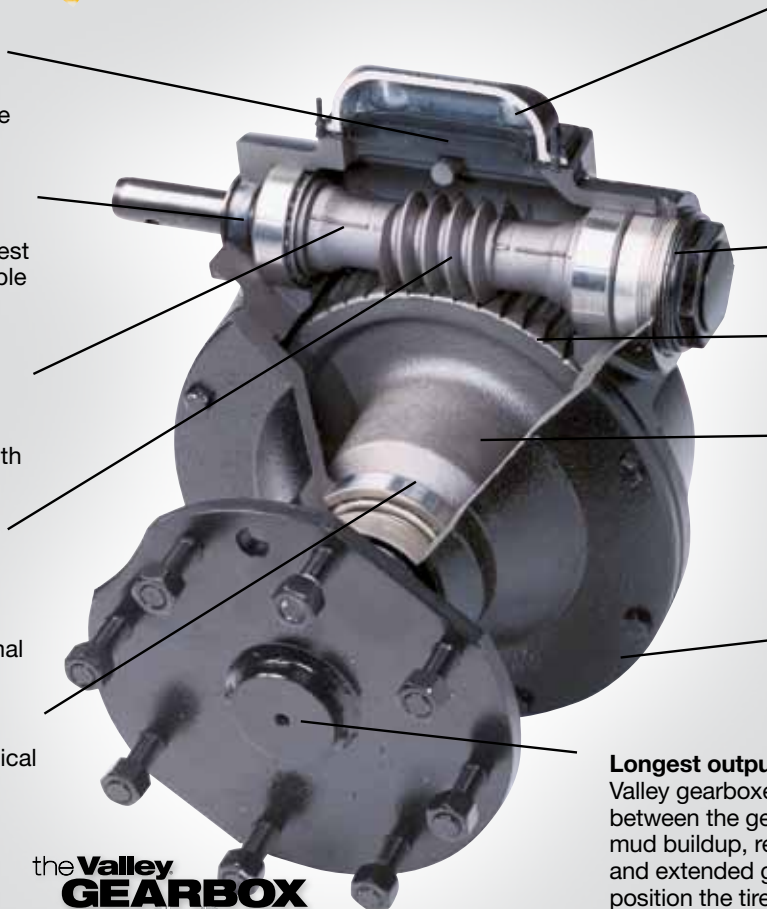

**Expansion chamber** — cap made of corrosion resistant cast aluminum; rubber diaphragm allows oil to expand and contract during operation. Vented cap prevents pressure buildup, prevents seal from leaking.

**Threaded endcap** — allows accurate bearing preload to increase bearing life.

**52:1 gear ratio** — full recessed tooth design keeps oil engaged between gears.

**Bull gear** — high strength cast iron provides the highest load capacity in the industry and longest life. Optional bronze gear is available for extreme conditions.

**Multi-viscosity gearbox oil** — exceeds 85w140 GL5 oil for long gear wear under extreme load conditions.

**Longest output shaft (steel)** — exclusive to Valley gearboxes. Provides extra clearance between the gearbox and wheel flange, reducing mud buildup, resulting in reduced seal damage and extended gearbox life. Special offset rims position the tire back close to the gearbox to minimize bearing loads... another Valley exclusive.

## Center Drive

The Valley Center Drive is built stronger, lasts longer, and uses less energy than other irrigation drive motors. Standard-speed and high-speed motors are available, with the standard-speed requiring the least amount of power in the industry.

- **Double output shaft seals** — Keeps oil in the motor and prevents dirt from entering the motor.
- **Built-in crop guard over U-joint** — Prevents crop wrapping in or near oil seals.
- **Case-hardened steel helical gears** — More teeth in mesh at all times for smoother power transmission.
- **Exclusive coating** — Applied to internal surfaces to prevent corrosion.
- **Finned aluminum housing** — For cool-running efficiency. Operates at temperatures lower than competitive motors.
- **Exclusive trapped gasket** — Ensures a water-tight seal.
- **Single-phase electric option** — For locations without three-phase power.



## VS-7000 Gearbox – 7000 series

**Input and output bearings** — Chinese through-hardened bearings.

**Worm gear** — high strength ductile iron provides significantly longer wear life than steel when combined with a cast iron bull gear.

**Tooth Design** —  $14\frac{1}{2}^\circ$  tooth angle

Shorter bull gear neck and keyway matching non-Valley gearboxes

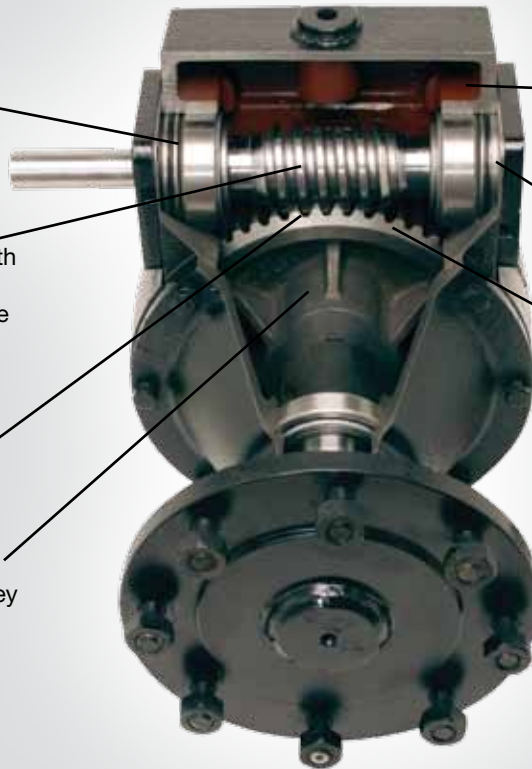

**Expansion chamber** — large open volume to minimize internal pressure changes with temperature changes.

Shims used to set bearing preload.

**52:1 gear ratio** — full recessed tooth design keeps oil engaged between gears.

**Long output shaft** — exclusive to Valley gearboxes. Provides extra clearance between the gearbox and wheel flange, reducing mud buildup, resulting in reduced seal damage and extended gearbox life. Special offset rims position the tire back close to the gearbox to minimize bearing loads...another Valley exclusive.

\*Only available on 7000 series  
Available in US and Canada only

## VS-7000 – Center Drive Choice\*

The VS-7000 center drive offers the performance you have come to expect from Valley but at a lower price point. The VS-7000 is similar to the original Valley center drive except that the VS-7000 has a corrosion resistant painted steel housing.

- Same performance specifications
- Same helical gearbox
- Same amp draw
- Same torque rating



\* Not available on the 8000 series. Only available in US & Canada

# Durable Valley Structure

From pivot point to end tower, the entire Valley structure is engineered, constructed and field-tested to handle the operating stresses that your machine may experience in its lifetime. Valley structures stand up to the toughest loads produced by rough terrain, furrows and long-span machines. No wonder Valley pivots, corners and linears command the highest resale value in the industry. Valley machines consistently outperform the competition in safety, durability, and strength, giving producers the most valued products the industry has to offer.

**With these features you can rest assured that you have the most durable structure the industry has to offer:**

- Hot-dip galvanized steel
- 4-leg drive unit with braces
- Ball-and-socket span hitch
- Heavy 8-bolt pipe flanges
- Welded sprinkler coupler
- Full wrap-around weldments
- Forged truss rod heads
- Polyurethane flange gaskets
- Evenly loaded spans
- Short extender pipes are never used to achieve span lengths

## Valley Spans

When making decisions that may affect yields and operation, look to Valley to provide the structural strength growers need to achieve maximum productivity. Valley spans continually and consistently outperform the competition.

- Pipe diameters of 5", 6 5/8", 8 5/8", and 10"
- Span lengths from 142' – 225'
- Galvanized steel comes standard
- PolySpan<sup>®</sup> pipeline available for corrosive conditions



## Fixed Pivot Points

Fixed pivot points offer maximum platform durability and are available in four sizes to fit growers' needs.

### 6 5/8" Pivot Point

- Designed for pivots up to 1,300' long
- Low and standard profile drive units available

### 8" Pivot Point

- Designed for pivots up to 1,500' long
- Low, standard, and high profile drive units available

### 8 5/8" Pivot Point

- Designed for pivots up to 2,800' long
- Low, standard, high, and ultra-high profile drive units available

### 10" Pivot Point

- Designed for pivots up to 2,800' long
- Standard, high, and ultra-high profile drive units available





**Xenoy Riser Nipples**  
 Help protect a grower's investment by ensuring durability and sealing at low pressures.



**Lateral and Radial Welds**  
 Additional strength from welding makes the machine more reliable.



**Truss Rods**  
 Large transition radius and uniform loading rod heads mean a lower concentration of stress and longer machine life.



**Drive Unit Legs**  
 Designed to carry uniform loads and provide machine stability.



**Leg Attachment Brackets**  
 These fully wrap around at each drive unit, which helps provide machine efficiency.



**Truss Rod Sockets**  
 Offer more machine strength and stability as a result of evenly loaded truss angles and forge-formed truss rods.



**Ball and Socket Hitch**  
 The single piece forged steel ball ensures smooth machine movement in all directions and less stressful rotation. This design helps lengthen a machine's lifespan.



**Sprinkler Outlet**  
 The welded coupler strengthens the pipeline around the water outlet and minimizes pressure loss. This design provides better support to u-pipe and drop pipe installations.



**Gearbox**  
 Longer output shaft and offset rim provide clearance between the gearbox and tire to reduce mud buildup and extend seal life.

## Valley Electrical Components



**Collector Ring**  
 Transfers incoming electric power to the pivot and utilizes a water tight seal. This comes standard with stainless steel electrical conduit to ensure years of trouble-free service.



**Span Cable**  
 The span cable options include: 8, 10 and 12 gauge wire for power and 14 gauge wire for control. Standard options include a shielded span cable and color-coded wire for easy service and maintenance.



**Tower Box**  
 Galvanized steel base construction with stainless steel shaft and nylon bearing assembly helps ensure long life.

# Valley Control Panels



## TouchPro™

The TouchPro control panel with touch technology is designed to provide you with powerful yet user-friendly control of your center pivots.

- Programming based on date, time, position, and other data
- Full-color main screen can be customized
- Designed for easy programming including: load management programming, graphical view of pivot position, end gun, and wide boundary positions
- Designed to meet extreme temperatures, high humidity, and transient voltage requirements

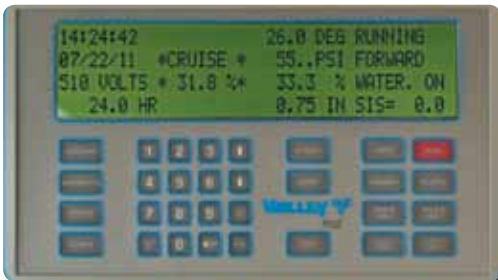

## Pro2

The technologically advanced Pro2 control panel gives you a simple set of tools for the highest level of control and monitoring, both in the field and remotely. This panel also features a patent pending Valley exclusive, Cruise Control, which allows automatic speed adjustment of your center pivot based on completing a defined number of degrees in a specific amount of time.

- Programmable functions based on date, time, and position
- Advanced diagnostics, such as system faults, error codes, and logs
- Advanced sensory and auxiliary functions
- Backlit screen and keypad come standard



## Select2

With its programmable features, the Select2 control panel incorporates the same field-proven processor technology as the Pro2.

- End gun, stop-in-slot, and auto reverse set in the panel
- Field sector controls to change water application for different crops or soils
- Auto restart on power, pressure, or both
- Pivot position reporting
- Backlit screen and keypad come standard



## AutoPilot Linear

The AutoPilot Linear control panel displays the position and direction of travel of the linear machine, allowing you to program linear operations based on those readings.

- Ability to change percent speed timer
- Turn primary and secondary end guns on/off
- Can program to change direction and stop
- Start/stop chemigation based on linear's field position



## ClassicPlus

The ClassicPlus control panel offers easy-to-operate switches for manual operation.

- Mechanical auto reverse
- Mechanical pressure switch to monitor for low pressure
- Percent timer dial to control application
- Optional mechanical switches to set pivot direction
- Can be upgraded to Valley Pro2, Select2, or AutoPilot Linear

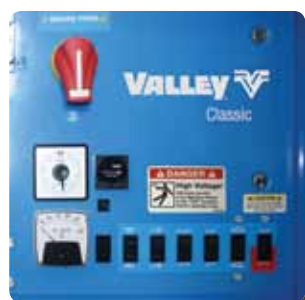

## Classic

The Classic control panel offers the lowest initial investment and provides push button, manual operation. It is designed for center pivots only.

- Push button operation
- Percent timer to control water application
- Optional mechanical switches to set pivot direction and monitor for low pressure

# Global Positioning System (GPS)

## GPS Guidance

PATENTED

- Available with linears and corners
- Eliminates the need for below-ground, above-ground, or furrow guidance options
- Can easily program the field map with the custom Valley mapping tool to best match changes in farm practices or field boundaries
- Diverse platform supports multiple brands of RTK receivers, such as John Deere® and Trimble®



GPS Guidance panel

## GPS Position

PATENTED

- Available with center pivots and linears
- Allows the grower to gather accurate data about the machine's position
- Can program control panels to more accurately apply different levels of water and crop protection/fertility products
- Is compatible with the NovAtel GPS receiver, which is a dual channel and does not require a correction to achieve +/- 10'
- Water is applied more efficiently offering a high yield potential and lower input costs
- Requires a GPS Ready TouchPro™, Pro2, Select2, or AutoPilot Linear control panel

# Advanced Control Technology

## Valley® BaseStation2-SM

The most advanced and complete remote irrigation management in the industry from Valley Irrigation combines the ability of remote monitoring and control with monitoring of soil moisture status of center pivot and linear irrigation equipment. The BaseStation2-SM is a dedicated, centralized irrigation management system for your computer, custom-designed for your application.

- Control and monitor one to hundreds of center pivots from your computer, Smartphone, or tablet
- Check pivot status and monitor soil moisture
- Generate reports that give you year-to-year comparisons
- Voice call-out
- Linears can be viewed and managed
- Updated linear mapping function includes drawings of hydrants, swing-around function, hose feed, and ditch feed
- Remote monitoring allows you to monitor all pivots on one screen to see an at-a-glance view of your pivot status
- PumpLink (Auxiliary Link) allows you to monitor data from a variety of pumps, sensors, valves, and other electrical components
- PanelLink allows you to use BaseStation2-SM with non-computerized Valley control panels and non-Valley panels



## Soil Moisture Monitoring

- Irrrometer® WATERMARK® soil moisture sensors allow irrigation scheduling to avoid over or under watering the field
- Allows you to read the level of moisture present within the soil at various depths
- The Irrrometer screen within BaseStation2-SM shows soil moisture information for all of your fields where sensors are installed
- View more detailed readings and history at [www.Irrrometer.com](http://www.Irrrometer.com)

Be everywhere at once with  
Valley BaseStation *Mobile*.

To see how BaseStation2-SM can put you back in control, request a FREE BaseStation2-SM demo today. E-mail your request to: [basestation@valmont.com](mailto:basestation@valmont.com)



**Contact Valley Irrigation for your FREE BaseStation2-SM demo.**



## Valley TrackNET™

No more driving long distances or going through fields in the middle of the night to check or stop your irrigation equipment. With Valley TrackNET, the family of Tracker products, you can remotely communicate with your center pivots and linears via Internet, Smartphone, mobile phone, or tablet, significantly decreasing costs and wasted time. View the Tracker demo at [www.ValleyTrackNET.com](http://www.ValleyTrackNET.com)



### TrackerLT

- Can be used on most brands of center pivots
- Utilizes GPS Position for programmable end gun and stop-in-slot positions
- Stops pivot
- Monitors direction, position, and water pressure (pressure transducer required)
- Create and set the speed for up to 9 sectors with the Independent Speed feature

### TrackerPro

- Designed specifically for non-Valley, Valley Classic, and Valley ClassicPlus control panels
- Allows the integration of Valley and non-Valley panels into the same management system
- Monitors machine status and allows you to control start, stop and directional changes remotely



### TrackerSP

- Can be used with the TouchPro™, Pro2, and Select2 control panels
- Reviews field diagnostics
- Monitors most remote features, including application depth, diagnostics, end guns, and field position
- Controls start/stop, water on/off, direction, and auxiliaries
- Communicates via cellular path
- Limited functionality with linear machines
- Now available in Spanish and French

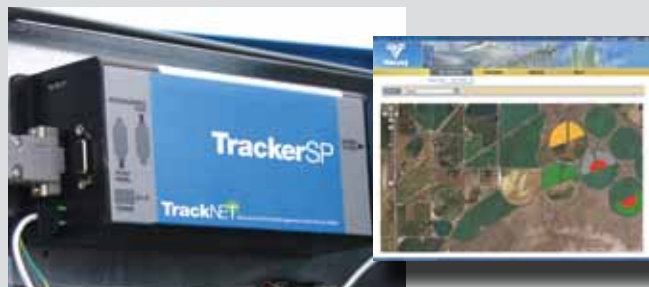

## Never miss a beat with Tracker *Mobile*.

The Tracker Mobile utilizes your Smartphone and the Internet to retrieve monitoring and control panel options from Valley Tracker products. To visit the Tracker Mobile website, log onto <http://m.ValleyTracker.com>.



**Log onto [ValleyTrackNET.com](http://ValleyTrackNET.com) for a full overview of the TrackNet product line!**

# Variable Rate Irrigation



Variable Rate Irrigation (VRI) from Valley is ideal for fields with multiple soil types and varying topography. With a combination of hardware and software, Valley VRI allows the grower to adjust the desired amount of water in a particular sector (VRI Speed Control) or management zone (VRI Zone Control). Irrigation applications with VRI can be programmed to match specific field conditions.

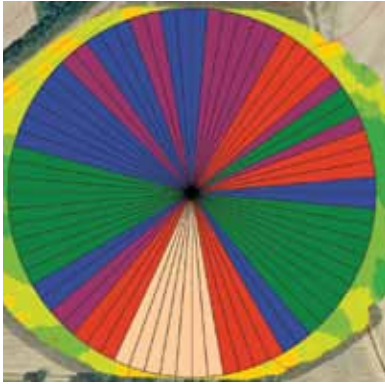

*VRI Speed Control -*  
One slice is one sector

## VRI Speed Control

- Sectors around the field are allowed every 2 degrees – up to a total of 180 sectors
- An uploaded VRI Prescription speeds up/slow down the pivot to achieve the desired application depth across a sector
- No additional hardware is needed to upload the prescription to the control panels
- Uses existing sprinkler package
- Either the Valley Pro2 or Select2 control panel, or the Valley Tracker LT is required

## VRI Zone Control

- Individual sprinkler or span control allows up to 30 different pivot zones along the center pivot and over 5,000 management zones within the field
- Can be used for on/off control for specific areas in a field such as ditches, canals, and wet areas
- An uploaded VRI Prescription turns control valves on/off along any pivot zone to achieve the desired application depth within a management zone
- Required hardware includes additional control valves for each sprinkler that will be managed by VRI Zone Control
- Uses Valley VRI tower boxes and a Valley Pro2 control panel

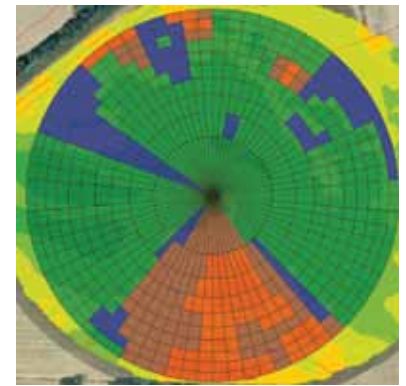

*VRI Zone Control -*  
One block is one management zone



*VRI Prescription Software*

## VRI Prescription Software

- Allows the creation of a Variable Rate Irrigation plan based on topography information, soil data maps, yield data, and other user-defined field information
- The prescription is uploaded to the control panel or TrackerLT to fully utilize VRI Speed Control and VRI Zone Control
- The prescription software is used on an external computer

## VRI Optimization

With Valley Variable Rate Irrigation Optimization growers now have access to powerful, agronomic tools that help precisely match application depths, via prescriptions, to soil type, topography, in-season imagery, and historical yields.



**Optimize irrigation on EVERY acre with Valley VRI!**

# Precise Water Application

Growers can depend on their Valley dealer to help them select the proper sprinkler package based on climate, soil type, crops, and topography.

- Sprinkler brands include Valley®, Senninger® and Nelson®
- Precise, computerized sizing and spacing of nozzles ensure application uniformity
- Low-pressure sprays operate as low as 6 psi, saving horsepower, energy and money
- Application efficiencies can reach 95%, depending on the design of the sprinkler package
- Additional sprinkler options include: end guns, sprinkler drops, boombacks and chemigation/fertigation equipment

## Valley Sprinklers



### Valley Low-Energy Nozzle (LEN)

- Wide variety of available pads
- Unique shape for movement through the crop
- Chemigation and part-circle pads
- Low pressure operation
- Single, double or triple deflector pads divide the nozzle flow into larger number of streams

## Nelson Sprinklers



### R3000 Rotator®

- Features the greatest throw distance available on drop pipes
- The wide water pattern from rotating streams equates to lower average application rates, longer soak time and reduced runoff
- More overlap with adjacent sprinklers improves uniformity

## Senninger Sprinklers



### Universal Pivot Products Platform (UP3)

- This design has been applied to the proven technologies of the i-Wob, Xi-Wob, LDN, and Super Spray
- Easy-clean nozzle – no need to disassemble or remove the sprinkler
- Integrated base and bracket – no special thread or fittings required

Additional sprinkler options from Nelson and Senninger available through Valley Irrigation.



## Updated Sprinkler Package

The most important investment you can make.

- New low-pressure sprinkler technology may reduce your energy cost
- Effectively operate sprinklers at 10 – 20 psi
- Provides efficiency and uniformity
- Droplet sizes designed for minimum wind drift
- Replace or add pressure regulators to achieve proper flows from each nozzle
- Valley Dealers are highly trained experts in water application and conservation

Increase water application efficiency on your machines

# Pipeline Solutions

## For corrosive water applications

### Facing Tough Choices?

Do environmental regulations require new treatment options for process water or livestock waste?

Does your water supply contain corrosive chemicals?

Do you add chemicals for crop or soil management?

Valley® has the solution for you.

Your Valley Dealer will help you decide which solution is best for you. Here are the pipe options available:

- PolySpan®
- Cathodic Anode
- Galvanized Steel



### PolySpan

- Patented design resists effect of acidic, alkaline, corrosive, and saline waters
- Prorated 20 year pipeline corrosion warranty with first 10 years unconditional replacement due to corrosion
- Manufactured in the USA
- Available with Valley pivots, towables, Precision Corner™ and linears (8 5/8" and 6 5/8" pipe)



### Galvanized Steel

- Extends machine life in a variety of water conditions
- Prorated 20 year corrosion warranty
- Available with all Valley equipment



### Cathodic Anode

- Replaceable anode extends machine life in salty water conditions
- Amount of protection (number of anodes) can be customized for your installation
- Available with all Valley equipment

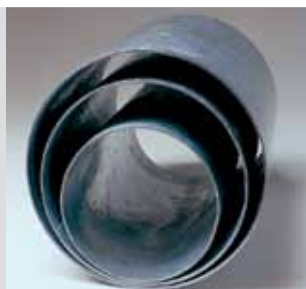

## Pipe Options

Choose from 6" , 6<sup>5</sup>/<sub>8</sub>" , 8<sup>5</sup>/<sub>8</sub>" and 10" pipe diameters to minimize pressure loss and horsepower requirements.

Now available with the 5000 series only, a 5" pipe option.

## Re-Piping – A Low-Cost Solution

- Re-piping is the most economical way to significantly extend the life of your machine.
- Valley offers three choices for re-piping:
  - PolySpan - for any corrosive water, crop protection and soil treatment chemicals
  - Galvanized Steel - for a variety of water conditions
  - Cathodic Anode - for machines with limited remaining life

Contact your local Valley dealer for a FREE Water analysis!

# Valley Floatation Solutions



Stuck pivot towers can cause costly downtime. Valley has the floatation option to help reduce wheel track depth, increase traction, and help keep your machines moving through your fields. Different floatation options are needed for different fields. Whether your terrain is rolling or flat or if you have sandy, loamy, sharky, or heavy soil your Valley dealer can help you decide which is right for you.



## Floatation Options

- Valley 2-Wheel Drive
- Valley 3-Wheel Drive
- Valley Track Drive
- Valley Articulating Track Drive
- Valley Articulating 4-Wheel Drive
- Valley Corner Dual Drive

# Valley Wheel Options



### Tire sizes

Choose the tire size that fits your needs: from 22.5" – 38" wheels and 11" – 18.4" tractor treads or wide turf.



### 38" Rim Reinforcement

Heavy-duty rim standard on 38" tires. Valley adds an industry exclusive 0.3" reinforcing plate to the industry's standard rim to ensure long life under extreme field conditions.

Non-reinforced rim option available on 7000 series only.



### Heavy-Duty Gearbox

Optional bronze gear and hardened steel worm provides longer life under severe field conditions.

# Non-Directional Irrigation Tires

## Firestone Champion Hydro ND

Valley is the only center pivot irrigation company to offer these revolutionary tires. Firestone designed the Champion Hydro ND specifically for irrigation applications to increase traction and lessen rutting. The patented, non-directional tread design has equal traction in both forward or reverse directions and no longer requires having both a front and rear tire. Available now in 14.9 x 24 and 11.2 x 38 sizes.



**Non-Directional Irrigation Tires are a Valley Exclusive!**

# Available Options

## CableGuard™ – Safeguard Your Investments

In recent years, many irrigation equipment users have experienced copper cable theft. Valley Irrigation offers a full line of products to help prevent and deter this crime, thus protecting your investment.

Valley CableGuard products range from making it extremely difficult to remove the cable to alerting you when a theft happens. Working together with your local Valley Dealer, you have the option to combine CableGuard products to best fit your budget and your theft deterrence needs.



### CableGuard Products

- GSM CableGuard Monitor
- Cable Armor
- Span Cable Clamps
- Stainless Steel Banding
- Flexible Steel Conduit

## Water Management Solutions

With the goal of conserving resources and improving life, Valmont Industries recognizes the multiple opportunities for reusing wastewater and utilizing lower quality water. Cascade Earth Sciences (CES), a Valmont company, specializes in taking the waste out of wastewater. They are uniquely qualified to develop and implement a comprehensive water management strategy for impaired waters. This strategy encompasses water, energy efficiency, agricultural production, and environmental protection for governments and multinational corporations worldwide. The philosophy is to utilize existing infrastructure in combination with site-specific water quality, soil, crop, and climate characteristics to develop a sustainable agricultural system that reclaims and utilizes water of lower quality and wastewater.



A **valmont** COMPANY  
Conserving Resources. Improving Life.



### CES Offers You

- More than 30 years of experience and hundreds of completed projects
- Proven solutions that integrate soil, agronomy, engineering, and irrigation
- Turnkey projects (design, permit, build, and operate)

### Municipal

- Valley equipment helps growers meet water needs and nutrient requirements
- Cities benefit from lower-cost wastewater management solutions
- Environment benefits from elimination of discharge to streams

### Industrial

- Eliminates discharge of wastewater into municipal facilities and/or streams
- Reduces capital investment and energy required for conventional treatment

### Agricultural

- Livestock confinement facilities use center pivots and linears to distribute liquid manure
- Plant nutrients in wastewater reduce the need for commercial fertilizer

Visit [www.cascade-earth.com](http://www.cascade-earth.com) for more information about CES!

# Improve the Reliability of Your Machine



## Control Panel Upgrades

Bring Valley technology to all your center pivots and linears

- A minimal investment for a maximum return in reliability
- Two panel choices from Valley to perform the basic pivot operations
- Four GPS Ready panel choices from Valley to perform advanced control needs
- A new control panel helps eliminate electrical shutdowns
- Control your machine safely and efficiently
- Almost all pivot brands can be updated with Valley control panel technology

## Conversions

### Gearbox and Center Drive Conversion

- Minimal investment for maximum improved performance
- 8 year / 8000-hour drive train warranty for complete conversions
- Significantly improve reliability and extend the life of your machine
- Complete and partial conversions available including oil hydraulic conversions
- Almost all pivot brands can be converted

### Tower Box Conversion

- High value for a minimal investment
- Substantially reduce electrical shutdowns on older pivots
- Proven reliability and durability on non-Valley pivots
- Almost all pivot brands can be converted

## Control Options



### Modified Alignment

Provides additional alignment sensitivity for your machine. Recommended for machines 1500 to 2000 feet long.



### Remote Panel Mount

Locate your panel where it is most convenient.



### End of Field Stop and/or End of Field Auto Reverse

Precisely stop or reverse your machine. Both post and skid barricade styles are available.

## Fast Service

**We Service All Brands:** Since the mid-1950s, more than 50 irrigation equipment manufacturers have come and gone. But it's no problem if you have an "orphan" machine. Valley Dealers are trained to service and install Valley parts for most other pivot brands. Our goal is to keep your equipment moving and doing its job—enabling us to earn your business, day after day.

**Valley Parts Availability:** Valmont invests in five factory owned parts distribution centers, to support your needs of fast and reliable service. These centers, along with extensive local dealership parts inventories, ensure that you have parts when you need them most.

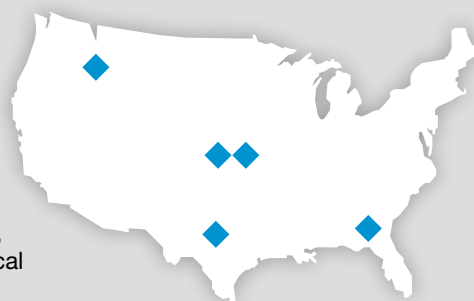

◆ Valmont Regional Parts Distribution Center

# Worldwide Leadership

Valley Irrigation is the world leader in designing and building efficient irrigation equipment for agriculture, industrial and municipal applications. Valley Irrigation founded the mechanized irrigation industry and remains dedicated to providing innovative solutions now and well into the future. The Valley brand has been recognized worldwide as the leader in sales, service, quality and innovation since 1954. With historical sales of more than 200,000 center pivots and linears, Valley Irrigation equipment annually irrigates approximately 25 million acres around the world.

**Valmont Industries, Inc.  
& Parts Distribution Center**  
McCook, Nebraska, USA

**Valmont Parts  
Distribution Center**  
American Falls, Idaho, USA

**Valmont Parts  
Distribution Center**  
Lubbock, Texas, USA

**Valmont Parts  
Distribution Center**  
Tifton, Georgia, USA

**CES**  
Albany, Oregon, USA

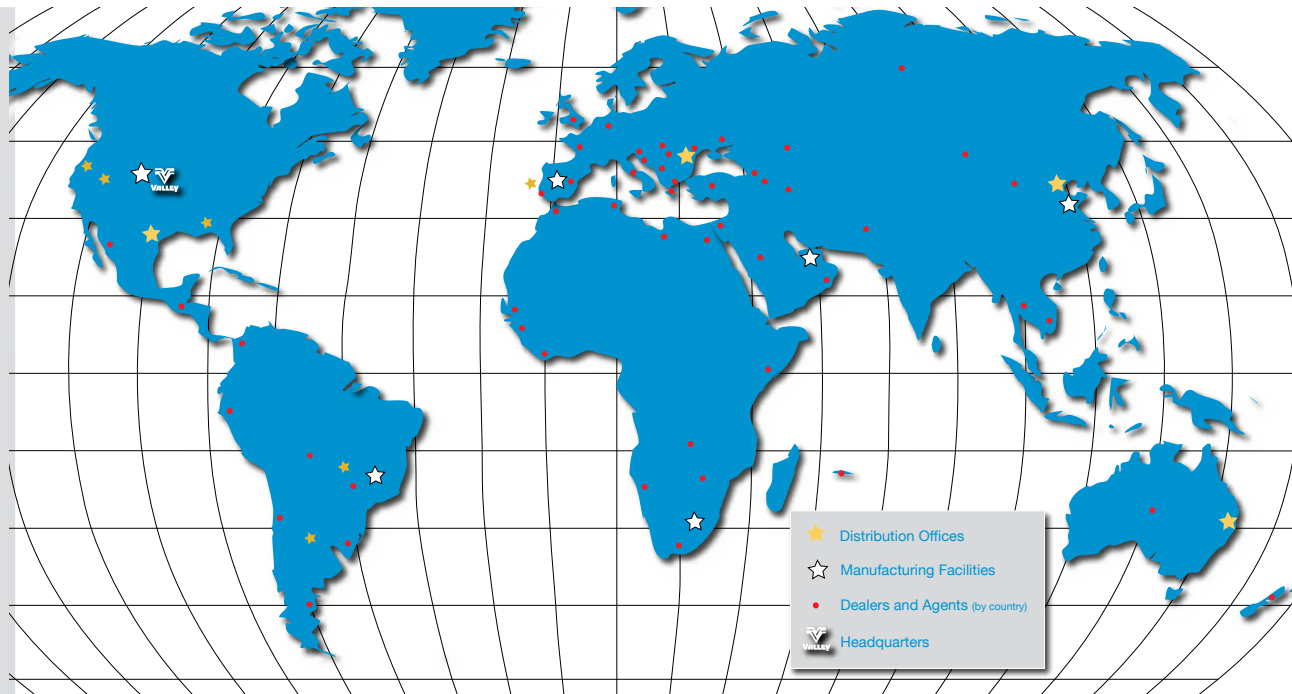

## World Headquarters

Valmont Irrigation  
28800 Ida St.  
P.O. Box 358  
Valley, Nebraska 68064-0358 USA  
Telephone: 1-402-359-2201  
Fax: 1-402-359-4948  
Email: [vinti@valmont.com](mailto:vinti@valmont.com)  
[www.valleyirrigation.com](http://www.valleyirrigation.com)

## Western Europe/Northern Africa

Valmont S.A.U.  
Ctra. La Poveda a Mejorada del Campo  
KM.9.300  
28840 Mejorada del Campo (Madrid)  
Spain  
Telephone: 34-91-679-4300  
Fax: 34-91-679-1677  
Email: [info.riego@valmont.es](mailto:info.riego@valmont.es)  
[www.valley-es.com](http://www.valley-es.com)

## Southern Africa

Valley Irrigation of Southern  
Africa (PTY) Ltd.  
P.O. Box 1234  
Pretoriusstad Nigel, 1490  
Republic of South Africa  
Telephone: 27-11-814-7007  
Fax: 27-11-814-4533  
Email: [info@valleyirrigation.co.za](mailto:info@valleyirrigation.co.za)  
[www.valley-za.com](http://www.valley-za.com)

## Middle East

Valmont Middle East FZE  
Plot # MO0781 & 782, R/A #12  
Street #1245, JAFZA  
P.O. Box 17937  
Jebel Ali, Dubai, U.A.E.  
Telephone: 9714-88-39740  
Fax: 9714-88-39567  
Email: [valmontme@valmont.com](mailto:valmontme@valmont.com)  
[www.valley-ae.com](http://www.valley-ae.com)

## South America

Valmont Industria E Comercio Ltda.  
Av. Francisco Podboy, 1600  
Distrito Industrial I  
Uberaba/MG - Brazil  
CEP 38056-640  
Telephone: 55-34-3318-9010  
Fax: 55-34-3318-9001  
Email: [comercial@valmont.com.br](mailto:comercial@valmont.com.br)  
[www.pivotvalley.com.br](http://www.pivotvalley.com.br)

## Eurasia

Valmont International LLC –  
Reprezentanta Romania  
str. Sica Alexandrescu #11 - sector 2  
022015 Bucuresti  
Romania  
Telephone: 40-72-267-7577  
Fax: 40-21-324-3328  
[vladimir.harminc@valmont.com](mailto:vladimir.harminc@valmont.com)  
[www.valley-ru.com](http://www.valley-ru.com)

## Australia-Pacific

Valmont Irrigation Australia Pty. Ltd.  
123 Cobalt Street  
P.O. Box 225  
Carole Park, Queensland 4300  
Australia  
Telephone: 61-7-3879-3622  
Fax: 61-7-3879-3655  
Email: [vaus@valmontinternational.com.au](mailto:vaus@valmontinternational.com.au)  
[www.valley-au.com](http://www.valley-au.com)

## Mexico & Central America

Valmont International Corp.  
2105 Mannix Drive  
San Antonio, TX 78217 USA  
Telephone: 1-210-829-7971  
Fax: 1-210-824-3233  
Email: [meellis@valmont-vice.com](mailto:meellis@valmont-vice.com)  
[www.valley-mx.com](http://www.valley-mx.com)

## Beijing, China

Valmont Representative Office  
Room 2 Suite 131  
Building #4  
Jianwai Diplomatic Compound  
1 Xiushui Street, Chao Yang District  
100600 Beijing, P.R. China  
Telephone: 86-10-8532-3512  
Fax: 86-10-8532-3510  
Email: [jin-ming.pang@valmont.com](mailto:jin-ming.pang@valmont.com)  
[www.valley-cn.com](http://www.valley-cn.com)

## Haiyang, China

Valmont Industries (Shandong) Co. Ltd.  
17 Jinan Road  
Haiyang Development Zone  
265100 Shandong, P.R. China  
Telephone: 86-21-3468-6612  
E-mail: [jian-hua.wu@valmont.com](mailto:jian-hua.wu@valmont.com)  
[www.valley-cn.com](http://www.valley-cn.com)



Conserving Resources. Improving Life.

28800 Ida St  
Valley, Nebraska 68064  
Phone: 402-359-2201 (Ext. 3415)  
Fax: 402-359-4429  
E-mail: [irrigation@valmont.com](mailto:irrigation@valmont.com)

International Fax: 402-359-4948  
E-mail: [vinti@valmont.com](mailto:vinti@valmont.com)

[www.valleyirrigation.com](http://www.valleyirrigation.com)

See your local authorized Valley Dealer for complete details.



Valmont<sup>®</sup> Irrigation has a policy of continuous product improvement and development. As a result, certain changes in standard equipment, options, price, etc. may have occurred after the publication of this brochure. Some photographs and specifications may not be identical to current production. Your local Valley<sup>®</sup> dealer is your best source for up-to-date information. Valmont Irrigation reserves the right to change product design and specifications at any time without incurring obligations.

©2012 Valmont Industries, Inc., Valley, NE 68064 USA. All rights reserved.

AD10098 C 8/12